



**KOLLER**  
FORSTTECHNIK

**GSK-4**



**KOLLER / GSK-4** 

**The latest invention of Koller - the grapple carriage GSK-4!**

TECHNICAL SPECIFICATIONS		ADVANTAGES
<b>Skyline</b>	Ø 20 - 32 mm	· Compact and robust design
<b>Mainline</b>	Ø 10 - 14 mm	· High quality components
<b>Weight</b>	1600 - 1800 kg	· Applicable with intermediate supports in standing skyline operations
<b>Payload</b>	4 t	· Capable for multispans skyline system
<b>Lifting cables</b>	2 x Ø 12 mm	· 4 skyline pulleys
<b>Engine power</b>	43 kW	· Large grapple opening width of 1820 mm (0,4 m <sup>2</sup> ) for quick picking of several trees
<b>Grapple capacity</b>	0,4 m <sup>2</sup>	· Powered by a 43 kW (59 PS) diesel engine
<b>Grapple opening width</b>	1820 mm	· Strong winch with 50 kN pulling force
		· Can also be used as lifting winch carriage
		· High lifting speeds of approx. 1 m/s with load
		· Extensive lowering height of 40 m
		· Remote control system with 3 cameras for safe and ergonomic operation from the control panel
		· TARS-system regulates the transport height by automatically raising and lowering the carriage to increase effective payload and driving speed
		· Optional skyline clamp for emergency clamping; also includes cable failure sensor



**KOLLER**  
FORSTTECHNIK

THE GSK-4 AT WORK

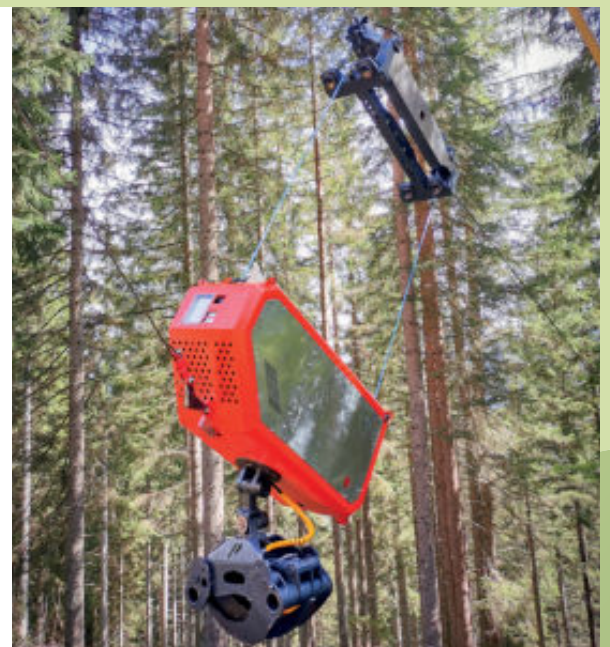
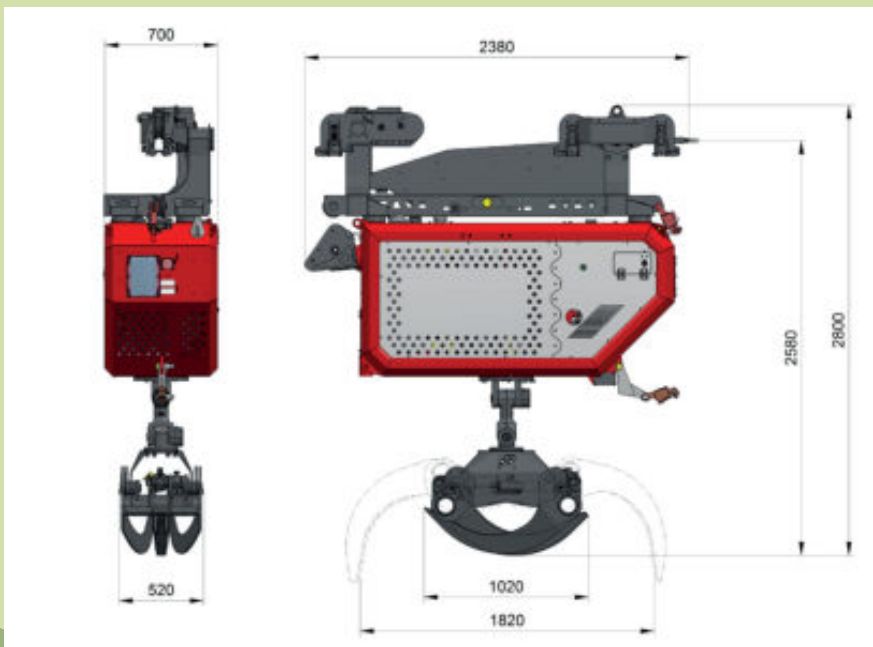

The quality of our products is the result of experience and continuous development since 1961. By using high quality components and the know-how of our employees, we can guarantee high productivity and good value stability.

Your local dealer

**Koller Forsttechnik GmbH**

Kufsteiner Wald 26

A-6334 Schwoich / Kufstein

T: +43 5372 63257 · F: DW -7

[www.kollergmbh.com](http://www.kollergmbh.com)



/KollerForsttechnik



/KollerForsttechnik



/kollergroup